

DecFill® LWF- Linear Walking Beam Filler Automatic Filling and Closing

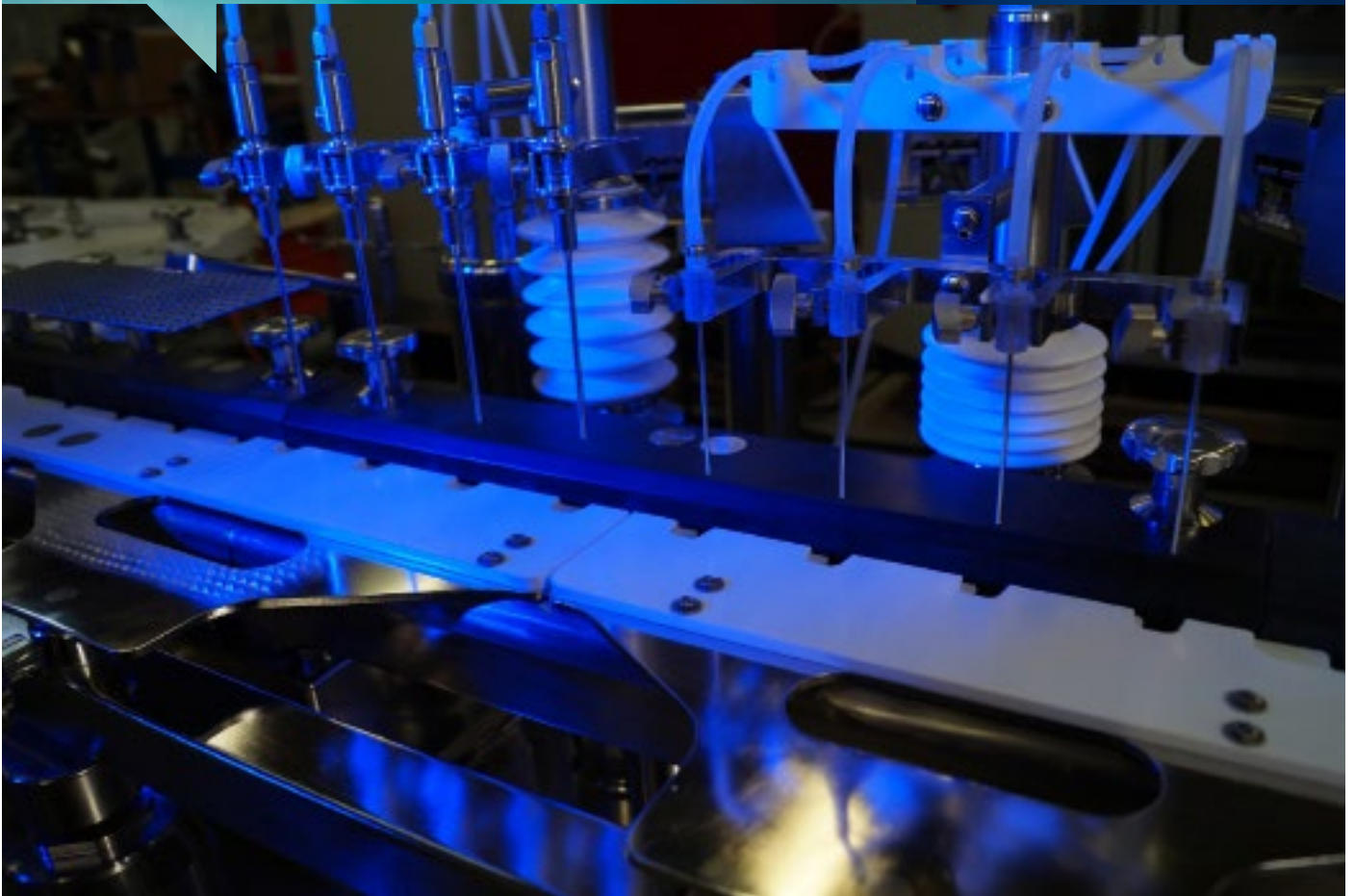

Automated filling and closing machine for bottles, vials, tubes, cartridges and other containers

- Tray load to rotary table vial in-feed
- Walking beam transport keeps glass containers separated
- Servo controlled filling needles for precise filling tolerance up to +/- 0.05%
- Up to 100% In process control verification
- Sorting bowls for closures such as stoppers and caps
- Vacuum activated placement of stoppers into vials
- Torque monitored crimp capping
- Particle counter detects and counts physical particles
- Separate container reject and discharge lanes
- RABS, Laminar Flow and/ or isolator

Technical Data	DecFill® LWF-2/4/6/8 (heads)
Output	up to 350 containers/min
Container Size Range	Ø 16 - 52 mm, H 30 - 130 mm
Dosing Range	0.01 - 10'000 ml
Electrical Supply	3 X 208 V, 50/60 Hz

DecFill® LWF- Linear Walking Beam Filler Automatic Filling and Closing

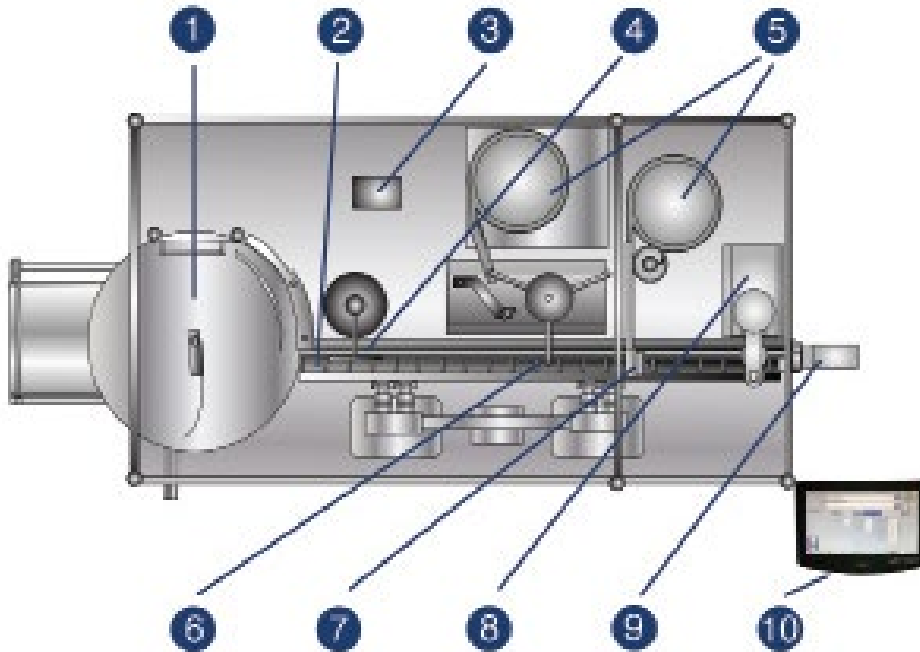

- 1 In-feed
- 2 Transport Walking Beam
- 3 Dosing Unit
- 4 Filling Station
- 5 Closure Sorting Bowls
- 6 Stopper Placement
- 7 Crimping Station
- 8 Reject
- 9 Discharge
- 10 HMI



Version 1 - Basic Machine



Version 2 - oRABS & LAF

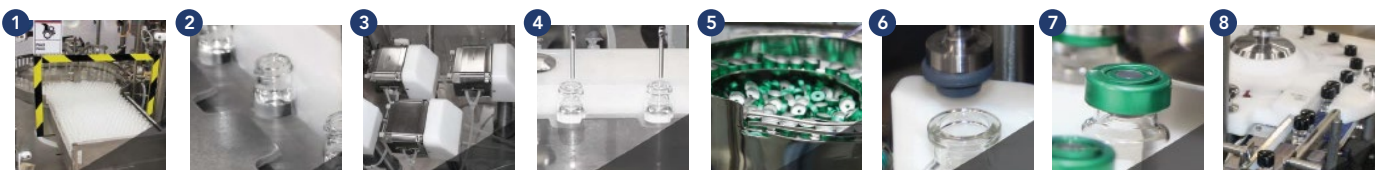

In-feed

Walking Beam

Dosing Units

Filling Heads

Sorting Bowls

Stoppering

Crimping

Reject/
Discharge